FUNCTIONAL OVERVIEW

Comfortio

Operator Desk System



Comfortio model B5 with optional equipment motorized base, double row monitor holders, light unit and noise dampening back panels.

Universal simplicity and functionality

Covering all your basic needs

A quality operator desk system for most applications. The desk and its ergonomic features exceed ISO 11064 & EEMUA 201 recommendations when equipped with the motorized frame. We offer a wide range of accessories that enables upgrades to meet future requirements.

Accessories for every need

With the wide range of accessories you'll find solutions to store computers or personal affects, arrange monitors, reduce noise, integrate non-glare light and personal sound system along with other technical equipment. In the end your customized desk will give you a space efficient solution, easy to clean and maintain.

A model for any design

The Comfortio desk system comes in a range of sizes and shapes. The desk system is useable for customized designs and to facilitate special equipment.

Design made easy

We have made all models available in CAD and Sketch up models for ease of use when designing your interior. We can also assist creating your next collaborative environment, please contact us for support.

A basic platform with expandable possibilities

- Adjustable light, always centered above workplace
- Monitor holder for best alignment of monitors
- Technical shelf that keeps computers off the floor and reduce the cabling problems that comes with height adjustment
- Protective back panels in noise reducing material

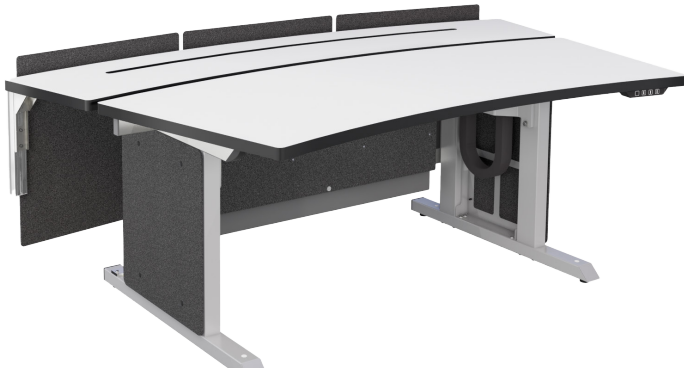

Standard desk models

- With optional motorized base 100-240V 50-60Hz
 - Monitor board: max load 150kg (depending on equipment level)
 - Work board: max load 150kg (depending on equipment level)
- Frame, columns and feet in silver RAL 9006
- Level adjustable feet
- High pressure laminate top board:

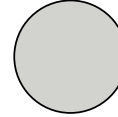

Formica 7927
Folkstone Light Gray



Formica 7921
Birch

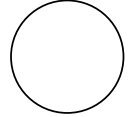

Other colors or
specifications are
available on request

Sizes

Monitors sizes based on 560 mm wide monitors, available as single and dual rows (First row + Second row). The amount of monitors refers to the motorized monitor board option only. Non motorized versions can always be equipped with double rows.

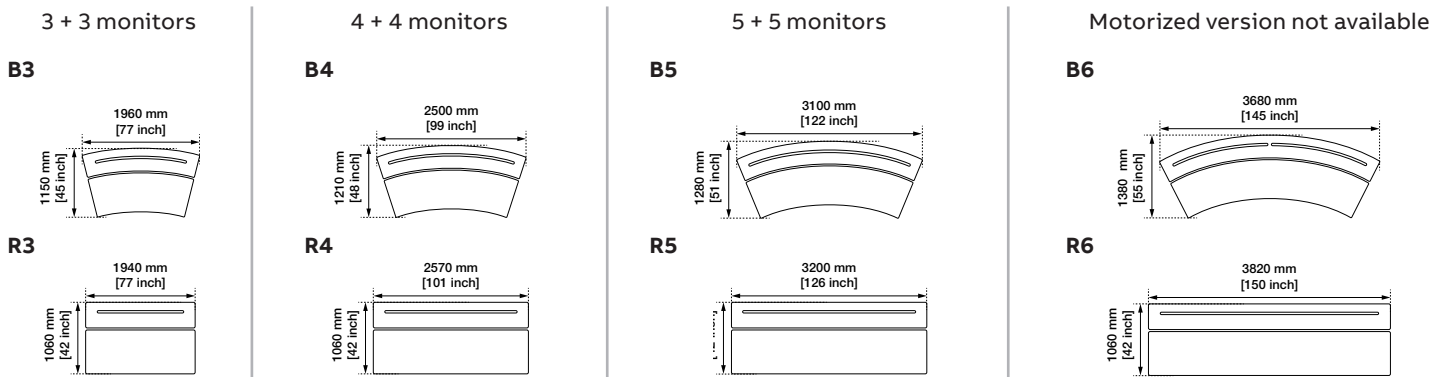

Details

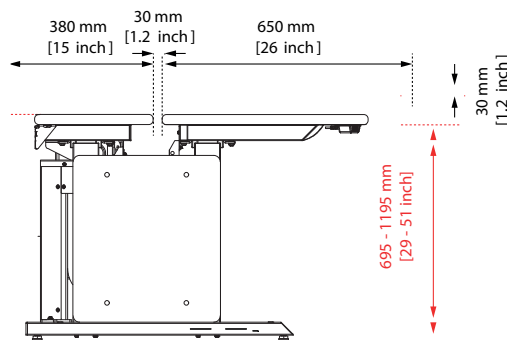
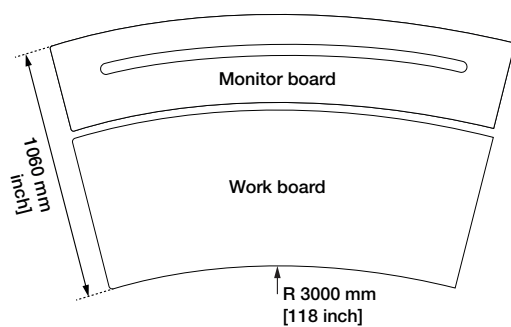

Optional: Motorized work board and monitor board enables height adjustments from 695 to 1195 mm.

abb.com
new.abb.com/control-rooms

All rights to other trademarks reside with their respective owners.

We reserve the right to make technical changes to the products or modify the contents of this document without prior notice. With regard to purchase orders, the agreed particulars shall prevail. ABB does not assume any responsibility for any errors or incomplete information in this document.

We reserve all rights to this document and the items and images it contains. The reproduction, disclosure to third parties or the use of the content of this document – including parts thereof – are prohibited without ABB's prior written permission.

Copyright © 2024 ABB
All rights reserved