

TECHNICAL DATA SHEET

# Type PG Nylon Locknuts Accessories

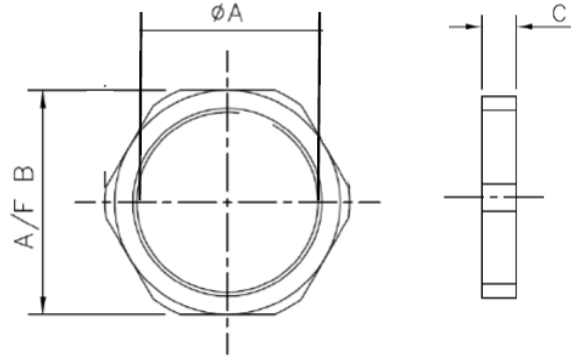

**Applications:**

- To be used with PG threaded non-metallic fittings when securing into knockouts

**Temperature range:**

- Static applications: -40°C to +100°C

**Ingress protection:**

- N/A

**UV Resistance:**

- Very high

**Material / Materials / Finishes:**

- Polyamide , fibre reinforced

**Fire performance:**

- Self extinguishing
- Halogen free

**Degree of mechanical protection:**

- Medium Impact resistance

**Chemical resistance:**

- Check polyamide in TDS 000081

Dimensions (mm)				
Part No. Black	Part no. grey	Thread (A)	A/F (B)	Thickness (C)
LNPB/PG7	LNPG/PG7	PG7	19.0	5.0
LNPB/PG9	LNPG/PG9	PG9	22.0	5.0
LNPB/PG11	LNPG/PG11	PG11	24.0	5.0
LNPB/PG13	LNPG/PG13	PG13	27.0	6.0
LNPB/PG16	LNPG/PG16	PG16	30.0	6.0
LNPB/PG21	LNPG/PG21	PG21	36.0	7.0
LNPB/PG29	LNPG/PG29	PG29	46.0	7.0
LNPB/PG36	LNPG/PG36	PG36	60.0	8.0
LNPB/PG48	LNPG/PG48	PG48	70.0	8.0