



Description

For the electronic measurement of currents : DC, AC, pulsed, mixed, with a galvanic isolation between the primary circuit and the secondary circuit.

Features

- ◆ Hall effect measuring principle
- ◆ Low power consumption
- ◆ Extended measuring range
Isolation voltage 3000 V
- ◆ Galvanic isolation between primary and secondary circuit



$$I_{PN} = 200 \dots 2000A$$

$$V_{OUT} = \pm 4 V$$

Advantages

- ◆ Easy installation
- ◆ Small size and space saving
- ◆ Only one design for wide current ratings range
- ◆ High immunity to external interference

Industrial applications

- ◆ DC motor drives
- ◆ Switched Mode Power Supplies(SMPS)
- ◆ AC variable speed drives
- ◆ Uninterruptible Power Supplies(UPS)
- ◆ Battery supplied applications
- ◆ Power supplies for welding application

TYPES OF PRODUCTS		
Type	Primary nominal current r. m. s I_{PN} (A)	Primary current measuring range I_P (A)
BSL-200IOV2M	200	±400
BSL-400IOV2M	400	±800
BSL-600IOV2M	600	±1200
BSL-800IOV2M	800	±1600
BSL-1000IOV2M	1000	±2000
BSL-2000IOV2M	2000	±3000

**Parameters Table**

PARAMETERS	SYMBOL	UNIT	VALUE	CONDITIONS
Electrical Data				
Supply voltage($\pm 5\%$) ⁽¹⁾	V _C	V	± 15	
Current consumption	I _C	mA	± 15	
Output voltage	V _{OUT}	V	± 4	@ $\pm I_{PN}$, R _L = 10 k Ω , T _A = 25°C
Isolation resistance	R _{IS}	M Ω	>1000	@ 500 VDC
Output internal resistance	R _{OUT}	Ω	100	
Load resistance ⁽²⁾	R _L	K Ω	>10	
Accuracy - Dynamic performance data				
Linearity ⁽³⁾ (0... $\pm I_{PN}$)	ϵ_L	% of I _{PN}	< ± 1	@ I _{PN} , T _A = 25°C
Accuracy	X	% of I _{PN}	< ± 1	@ I _{PN} , T _A = 25°C (excluding offset)
Electrical offset voltage	V _{OE}	mV	< ± 20	@ T _A = 25°C
Hysteresis offset voltage	V _{OH}	mV	< ± 10	@ I _p = 0
Temperature coefficient of V _{OE}	TCV _{OE}	mV/K	< ± 1	
Temperature coefficient of V _{OUT}	TCV _{OUT}	%/K	< ± 0.1	
Response time	t _r	μ S	<5	@ 90% of I _{PN}
Frequency bandwidth ⁽⁴⁾	BW	kHz	DC~25	@ -3dB
General data				
Ambient operating temperature	T _A	°C	-40...+85	
Ambient storage temperature	T _S	°C	-40...+105	
Mass	m	g	300	
Isolation characteristics				
Rated isolation voltage rms	V _b	V	1000	
Rms voltage for AC isolation test	V _d	kV	3	@ 50 Hz, 1 min

Notes:

- (1) Operating at $\pm 12V \leq V_C \leq \pm 15V$ will reduce the measuring range.
- (2) If the customer uses 10K Ω of the load resistor, the primary current has to be limited as the nominal.
- (3) Linearity data exclude the electrical offset.
- (4) Please refer to derating curves in the technical file to avoid excessive core heating at high frequency.

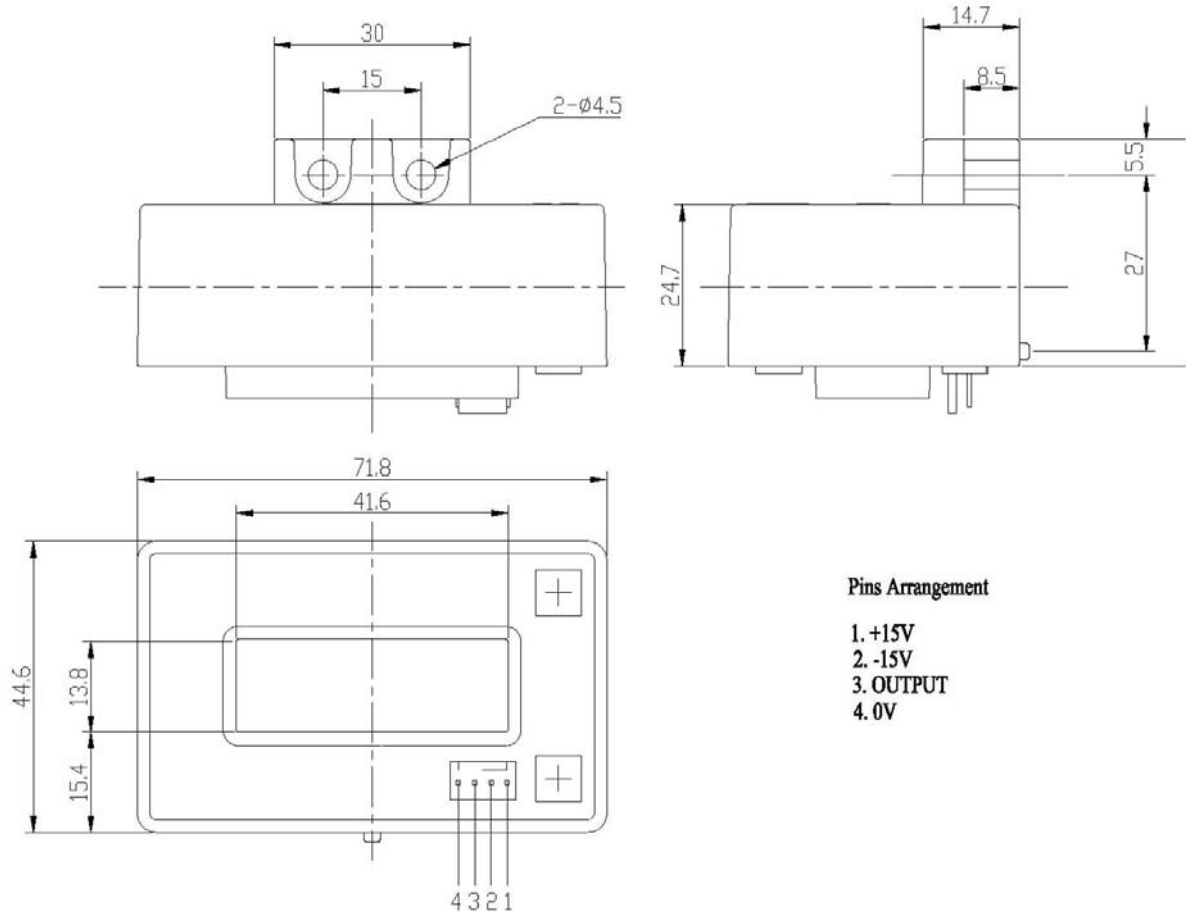
Dimensions BSL-IOV2M (in mm. 1 mm = 0.0394 inch)**◆ Instructions of use**

1. When the test current passes through the sensors you can get the size of the output voltage.
(Warning: wrong connection may lead to sensors damage)
2. Based on user needs, the sensors output range can be appropriately regulated.
3. According to user needs, different rated input currents and output voltages of the sensors can be customized.



RESTRICTIONS ON PRODUCT USE

- The information contained herein is subject to change without notice.
- BYD Microelectronics Co., Ltd. (short for BME) exerts the greatest possible effort to ensure high quality and reliability. Nevertheless, semiconductor devices in general can malfunction or fail due to their inherent electrical sensitivity and vulnerability to physical stress. It is the responsibility of the buyer, when utilizing BME products, to comply with the standards of safety in making a safe design for the entire system, including redundancy, fire-prevention measures, and malfunction prevention, to prevent any accidents, fires, or community damage that may ensue. In developing your designs, please ensure that BME products are used within specified operating ranges as set forth in the most recent BME products specifications.
- The BME products listed in this document are intended for usage in general electronics applications (computer, personal equipment, office equipment, measuring equipment, industrial robotics, domestic appliances, etc.). These BME products are neither intended nor warranted for usage in equipment that requires extraordinarily high quality and/or reliability or a malfunction or failure of which may cause loss of human life or bodily injury (“Unintended Usage”). Unintended Usage include atomic energy control instruments, airplane or spaceship instruments, transportation instruments, traffic signal instruments, combustion control instruments, medical instruments, all types of safety devices, etc.. Unintended Usage of BME products listed in this document shall be made at the customer’s own risk.