

Fiber Optic Field Bus System FFI

Yoshimi Watanabe

1. Introduction

The FFI (Fiber-optic Field Instrumentation) system is the first commercially available advanced field bus system to use optical fibers in the physical layer. These systems have been supplied to many customers. FFI has increased the economical efficiency and reliability of field instrumentation.

The goal of FFI system development was to expand and further the evolution of optical field instrumentation. The result is that most current instrumentation system structures are completely optical, including those developed jointly with leading equipment manufacturers.

This paper will present a simple explanation of the FFI

system structure and at the same time introduce available FFI field equipment products. The current status of the movement to establish international standards for the optical field bus is also discussed.

2. FFI System Configuration

The overall FFI system configuration is shown in Fig. 1. The system consists of field equipment, optical star couplers and master stations. A microprocessor provides the intelligence to the FFI field equipment. FFI field instruments is connected with a single optical fiber to an optical star coupler, which branches and gathers optical signals, or a master station, which interfaces to the host system.

Fig. 1 Overall FFI system configuration

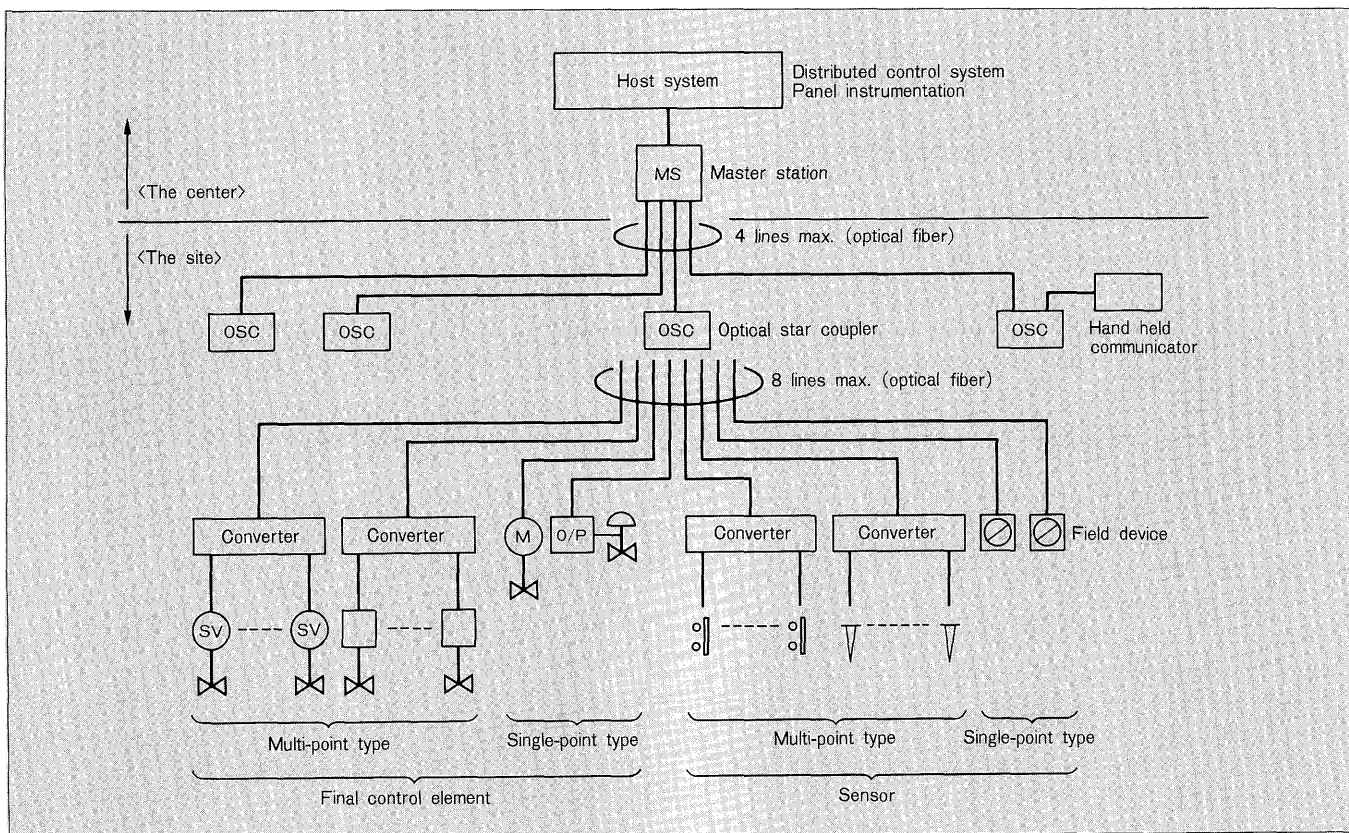

Table 1 List of FFI field device

Classification	Type	Product name	Main specification	Power supply	Type of explosion proofing
Sensor	Single-point type	Optical platinum resistance bulb temperature transmitter	-50 to 500°C	A	I
		Optical thermocouple temperature transmitter	0 to 300°C	A	I
		Optical gauge pressure transmitter	0 to 50,000kPa	A	I
		Optical gauge pressure transmitter with remote seal diaphragm	0 to 50,000kPa	A	I
		Optical absolute pressure transmitter	0 to 2,900kPa abs	A	I
		Optical differential pressure/flow transmitter	0 to 3,000kPa	A	I
		Optical differential pressure transmitter with remote seal diaphragm	0 to 500kPa	A	I
		Compact electromagnetic flowmeter	2.5 to 150A	B	D
		Optical variable-area type flow transmitter	15 to 300A	A	I
		Optical positive displacement type flow transmitter (Oval wheel flowmeter)	10 to 300A	A	I
		Optical turbine flowmeter	6 to 600A	A	I
		Optical flange type liquid level transmitter	0 to 500kPa	A	I
		Optical immersion type level/pressure transmitter	0 to 392kPa	A	I
		Optical tubular-float-displacement type level transmitter	3.5 to 30kPa	A	I
		Optical tank level transmitter	0 to 50m	B	D
		Optical pH meter	pH 0 to 14	A	I
		Optical signal converter	E-O converter	B	D
	Multi-point type	Optical multi-point temperature transmitter	16 points max.	B	I
		Optical inflammable gas detecting system	Flammable gas, 8 points	B	D
		Optical switch converter	Optical limit switch } 16 points Optical pressure switch } max.	B	I & D
Contact signal converter		16 points max.	B	D	
Final control element	Single-point type	Optical/pneumatic positioner	19.6 to 98.1kPa, 39.2 to 196.1kPa	A	I
		Optical/pneumatic converter	19.6 to 98.1kPa, 39.2 to 196.1kPa	A	I
		Optical electric actuator	Valve actuator	B	D
		Optical signal converter	O-E converter	B	D
	Multi-point type	Optical switching valve converter	For optical switching valve 8 points	A	I
Contact signal converter		For solenoid valve 8 points	B	D	
Other		Optical field indicator	LCD 4 digits	A	I
		Optical star coupler	8 : 3 branches, 2 : 1 branches	-	-
		Optical repeater	5.2km	B	I & D

Power supply A: Internal battery B: External power supply

Type of explosion proofing I: Intrinsic safety D: Flame-proof

Eight field equipment devices may be connected to a single optical star coupler.

Data from the eight field equipment devices are transmitted between the optical star coupler and the master station over a field bus consisting of a single optical fiber with half-duplex bidirectional transmission.

The master station can process up to a maximum of four channels (bus lines from four optical star couplers).

Therefore, one master station can support up to 32

field equipment devices.

3. FFI Field Equipment List

As shown in the system configuration of Fig. 1, FFI field equipment can be broadly classified as either sensors or final control elements. Each device can be further classified as single-point type optical sensors and optical final control elements, or as multi-point type. Several multi-

Fig. 2 Block diagram of single-point type sensor

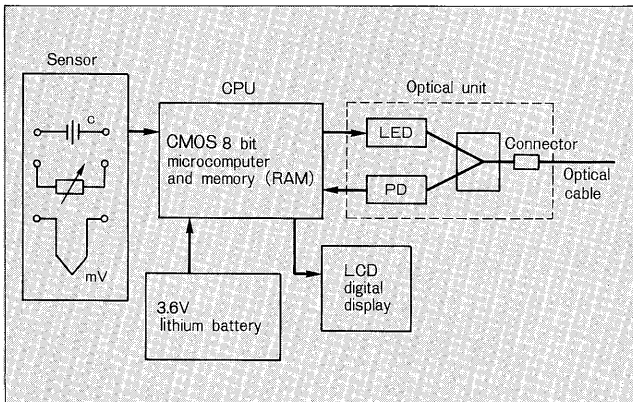

Fig. 3 External view of single-point type sensor (differential pressure/flow transmitter FFK)

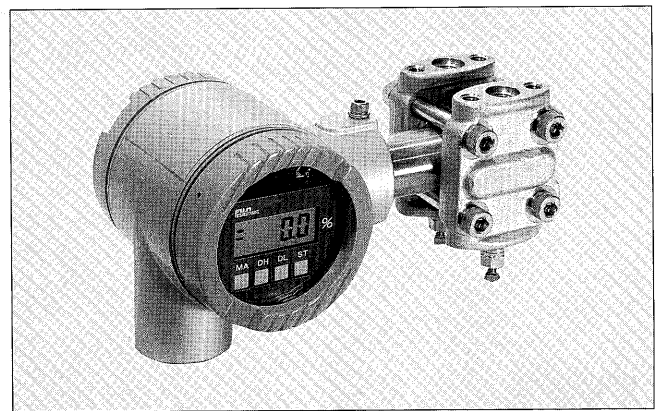
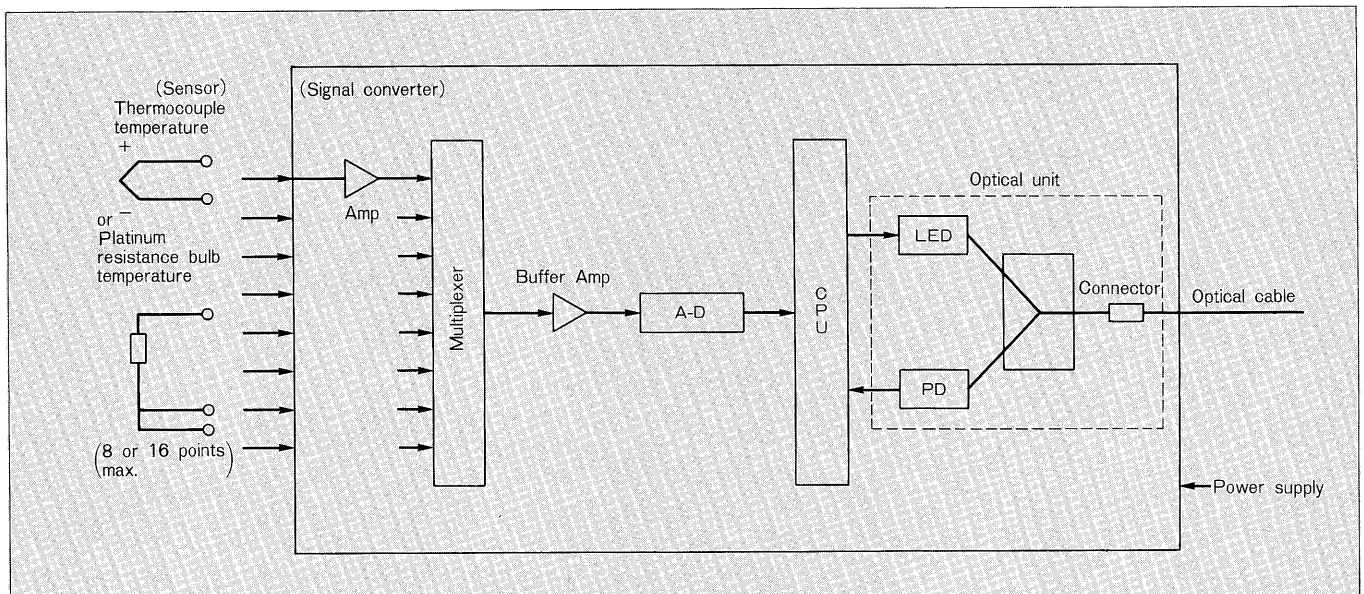

Fig. 4 Block diagram of multi-point temperature converter



point type sensors and final control elements are scanned to provide multiplexed optical data transmission.

Table 1 lists the main specifications, power supply method, and type of explosion-proof constructions for FFI field devices based on the above classifications.

The configuration in Fig. 1 shows the sensor and final control element with two single-point and multi-point type devices each for the star coupler. Up to eight devices may be connected to the optical star coupler in any combination.

The structure of single-point and multi-point type sensors is discussed in the following sections.

3.1 Single point type sensor

A block diagram of the typical single-point sensor is shown in Fig. 2. Most single-point type sensors use CMOS IC with low power consumption and low voltage requirements, enabling operation with internal lithium battery. Intrinsic safety against explosion eliminates the necessity

of a safety barrier. When these sensors are combined with optical fiber transmission, the simplest single-fiber optical system can be realized.

The structure consists of a sensor section and a transmission section in which microprocessor based electronic circuitry and a battery are incorporated. An optical fiber cable is connected to the transmission section's optical connector. Output signal and internal memory contents can be verified on the spot with the LCD display.

The external view of a single-point type sensor is shown in Fig. 3.

3.2 Multi-point type sensor

A block diagram of an optical multi-point temperature converter is shown in Fig. 4.

This converter, connected to eight or sixteen platinum resistance bulbs or thermocouples will work in the field to convert the output signals to an optical multiplexed signal. The output of each thermometer is scanned by the con-

Fig. 5 External view of multi-point temperature converter (FRL)

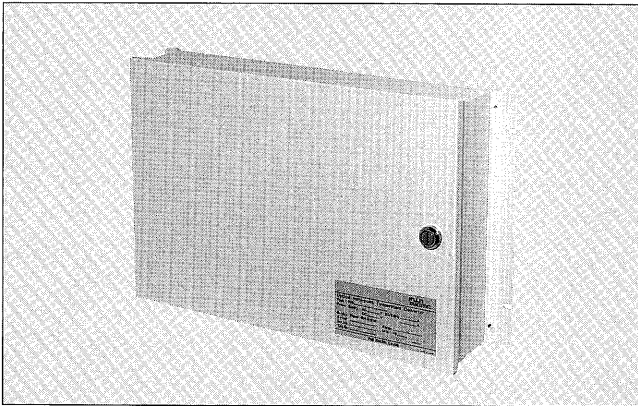

verter and an optical multiplexed signal is transmitted every 0.2 seconds.

The external view of a multi-point temperature converter is shown in Fig. 5.

The multi-point type sensor takes measurements at many points and therefore requires an external power supply. Prevention against explosions is in the form of intrinsic safety combined with a safety barrier or a flame-proof.

4. International Standardization of the Optical Field Bus

The establishment of international standards for field buses has been taking place since 1986. Proposals for optical systems based on the FFI system have also been made during this time. However, when it came to deciding actual specifications and drafting a proposal, the necessity of being able to retrofit to existing electrical systems was given preference. Standardization of the optical field bus will therefore come after electrical systems are standardized. The history of activities towards the international standardization of the optical field bus is shown in Table 2. Work to develop specific standards for the optical field bus began at an international conference in June 1992. Proposals were made by France's Telemecanique Inc. (high speed 1M, 2.5Mbps) and Fuji Electric (low speed 31.25 kbps). The contents of each proposal are shown in Table 3.

Deliberations on optical field bus standards were held in talks on November 1992 and March 1993 and will continue. A draft of proposed optical standards, based on the

Table 2 History of activities for international standardization of the optical field bus

Date	Location	Contents (Company which submitted proposal)
May 1987	Heidelberg	Optical field bus proposals. Rough drafts presented. (Fuji Electric, Japan)
February 1988	Phoenix	Draft proposals. Deliberations continue. (Fuji Electric, Japan)
June 1992	Frankfurt	Work begins to draw up a draft. (Fuji Electric, Japan; Telemecanique, France)
November 1992	Holland	Draft proposals, deliberations (Fuji Electric, Japan; Telemecanique, France)
March 1993	Paris	Draft proposals, deliberations (Fuji Electric, Japan; Telemecanique, France)

Table 3 Optical field bus proposal contents

Item	Telemecanique	Fuji Electric
Topology	Two fibers Active star	One fiber or two fibers Passive star
Bit rate	1Mbps, 2.5Mbps	31.25kbps
Fiber	62.5/125 μm (Test fiber)	100/140 μm (Test fiber)
Connector	ST connector	FC connector

electrical standards, is being rapidly drawn up. The Draft International Standard (DIS) which consumed six years when electrical standards were being established, is expected to be completed within the current year for optical standards.

5. Conclusion

The FFI field device product list and the current status of international standardization activities for the optical field bus have been presented. Sensor and final control element products have been improved to the point where almost every conceivable field bus structure can be realized by arranging opto-electric and electro-optic converters.

Cost performance considerations will determine whether a system is designed with single-point or multi-point sensors and final control elements.

Due to space limitations, this paper only dealt with sensor issues. Final control elements will have to be discussed at a later date. It is hoped that the reader will be aware of and watch for developments in the standardization of the optical field bus.