

REV.	ECN No.	APPD.
A	IC020635	Yihsin Chen 2/8,02
B	BC-06-779605	Yusan
C	BC-07-705535	Yusan
D	BC-08-7061976	Jake W.Yuan
E	BC-09-7074916	Yihsin Chen

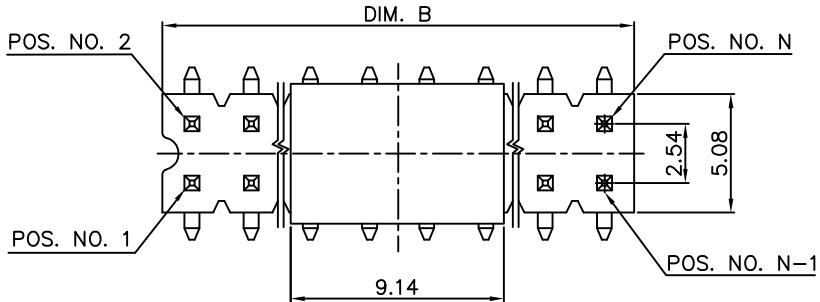

- NOTES: UNLESS OTHERWISE SPECIFIED
- DIMENSIONS SHALL BE INTERPRETED PER ASME Y14.5-1994.
  - SPEC. OF PROD. ARE SHOWN ON DRAWING "307-0100-239".
  - MATERIALS OF PARTS ARE SHOWN ON DRAWING "307-0500-241".
  - △ PRODUCT NO. MATRIX: PLEASE REFER TO "307-0300-241".
  - HARMFUL MATERIAL CONTROL PLEASE REFER TO FOXCONN'S DOC. "EPI12".
  - PLEASE CONTACT FOXCONN SALES REPRESENTATIVE TO VERIFY PRODUCT DETAILS & AVAILABILITY.

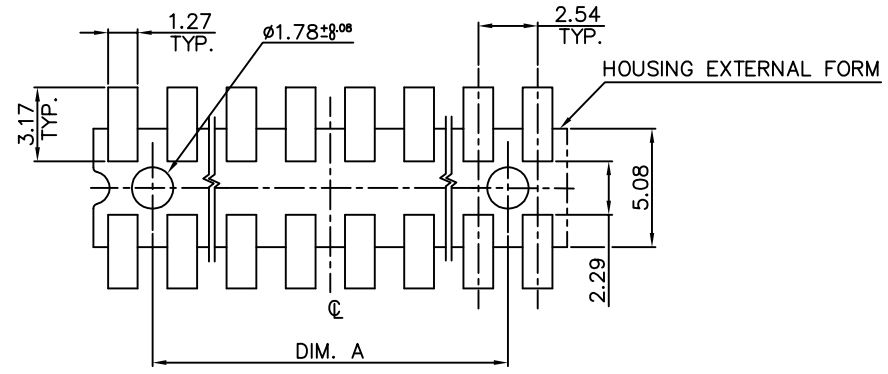
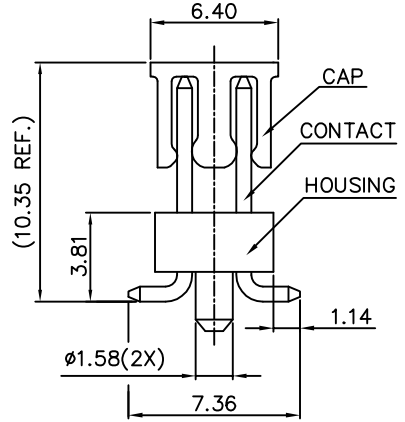
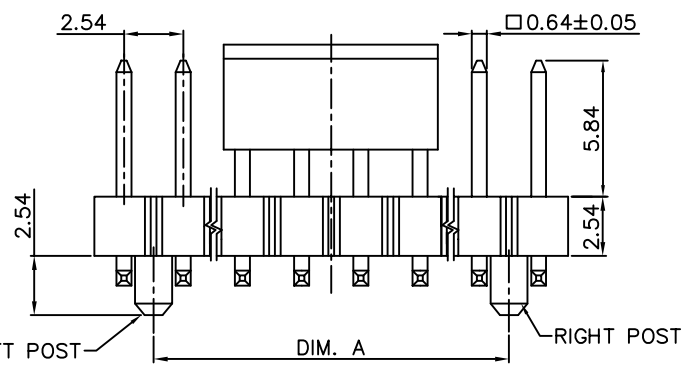

RECOMMENDED P. C. B. LAYOUT  
TOLERANCE ±0.05

HS1120*-****	20/40	45.72	50.80
HS1115*-****	15/30	33.02	38.10
HS1110*-****	10/20	20.32	25.40
HS1108*-****	8/16	15.24	20.32
HS1107*-****	7/14	12.70	17.78
HS1105*-****	5/10	7.62	12.70
HS1104*-****	4/8	5.08	10.16
HS1103*-****	3/6	2.54	7.62
PROD. NO.	POS. NO.	DIM. A	DIM. B

X.±	X°±	UNITS mm	NAME(INTENDED USE)	<b>FOXCONN</b> HON HAI PRECISION IND. CO.,LTD. TAIPEI, TAIWAN, R.O.C.				
.X± ±0.38	.X°±	MAT'L	HEADER CONN.					
.XX± ±0.25	.XX°±	FINISH	PART NO.(INTENDED USE)	TITLE: CUSTOMER DRAWING VERTICAL,2.54mm PITCH,SMT				
.XXX±	.XXX°±		HS11 SERIES	APPD: Yihsin Chen	DWG NO.: 307-0100-241			
THESE DRAWINGS AND SPECIFICATIONS ARE THE PROPERTY OF HON HAI PRECISION IND. CO., LTD. AND SHALL NOT BE REPRODUCED, COPIED OR USED IN ANY MANNER WITHOUT THE PRIOR WRITTEN CONSENT OF HON HAI PRECISION IND. CO., LTD.			Q'TY	CHKD: Wolfe Liu				
			DR: Fenghua Yu 7/14'09		<table border="1"> <tr> <td>SCALE</td> <td>SHEET</td> <td>REV.</td> </tr> <tr> <td>N/A</td> <td>1/2</td> <td>E</td> </tr> </table>	SCALE	SHEET	REV.
SCALE	SHEET	REV.						
N/A	1/2	E						

REV.	ECN No.	APPD.

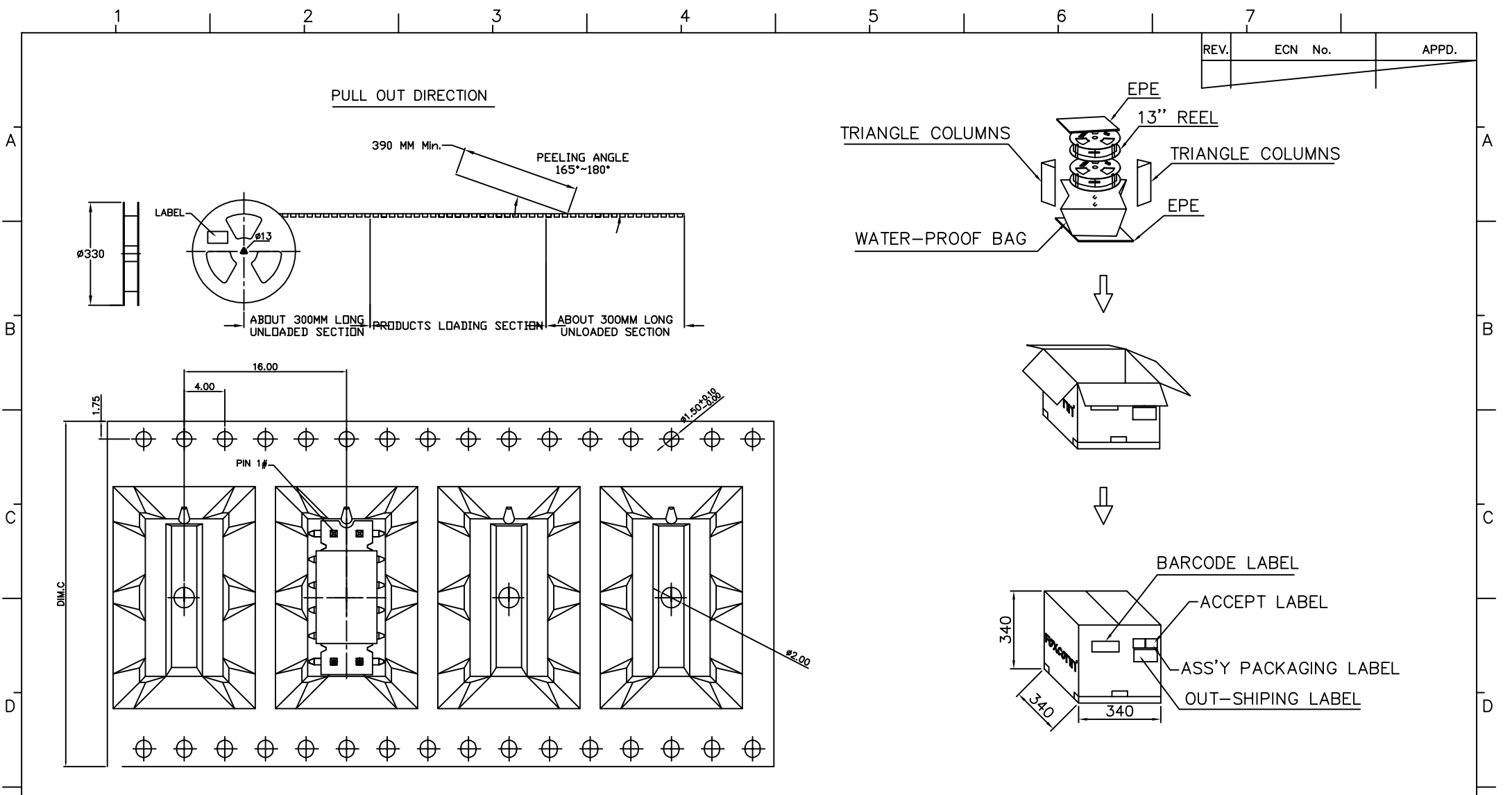

HS1120*-****	72.00
HS1115*-****	56.00
HS1108*-****	44.00
HS1107*-****	32.00
HS1105*-****	32.00
HS1104*-****	32.00
HS1103*-****	32.00
P/N	DIM.C

X.±	X°±	UNITS mm	NAME(INTENDED USE)	<b>FOXCONN</b> HON HAI PRECISION IND. CO.,LTD. TAIPEI, TAIWAN, R.O.C.
.X± ±0.38	.X°±	MAT'L	HEADER CONN.	
.XX± ±0.25	.XX°±	FINISH	PART NO.(INTENDED USE)	TITLE: CUSTOMER DRAWING
.XXX±	.XXX°±		HS11 SERIES	VERTICAL,2.54mm PITCH,SMT
THESE DRAWINGS AND SPECIFICATIONS ARE THE PROPERTY OF HON HAI PRECISION IND. CO., LTD. AND SHALL NOT BE REPRODUCED, COPIED OR USED IN ANY MANNER WITHOUT THE PRIOR WRITTEN CONSENT OF HON HAI PRECISION IND. CO., LTD.			APPD: Yihsin Chen	DWG NO.: 307-0100-241
			Q'TY	CHKD: Wolfe Liu
			DR: Fenghua Yu7/14'09	N/A 2/2 E

ITEM	DESC.	Q'TY	MATERIAL	TREATMENT	REMARK
1	HOUSING	1	HIGH TEMPERATURE THERMOPLASTIC, LCP,UL 94V-0	COLOR BLACK OR IVORY	
2	CONTACT	SEE NOTES BELOW	COPPER ALLOY	A) 50u" MIN. NICKEL UNDER PLATING OVER ALL B) MATTE TIN PLATING ON TAIL AREA C) MATTE TIN OR GOLD PLATING ON ON CONTACT AREA (SEE NOTES BELOW)	
3	CAP	1	HIGH TEMPERATURE THERMOPLASTIC, PA9T,UL 94V-0	COLOR BLACK	

NOTES :

1. PRODUCT No. MATRIX:

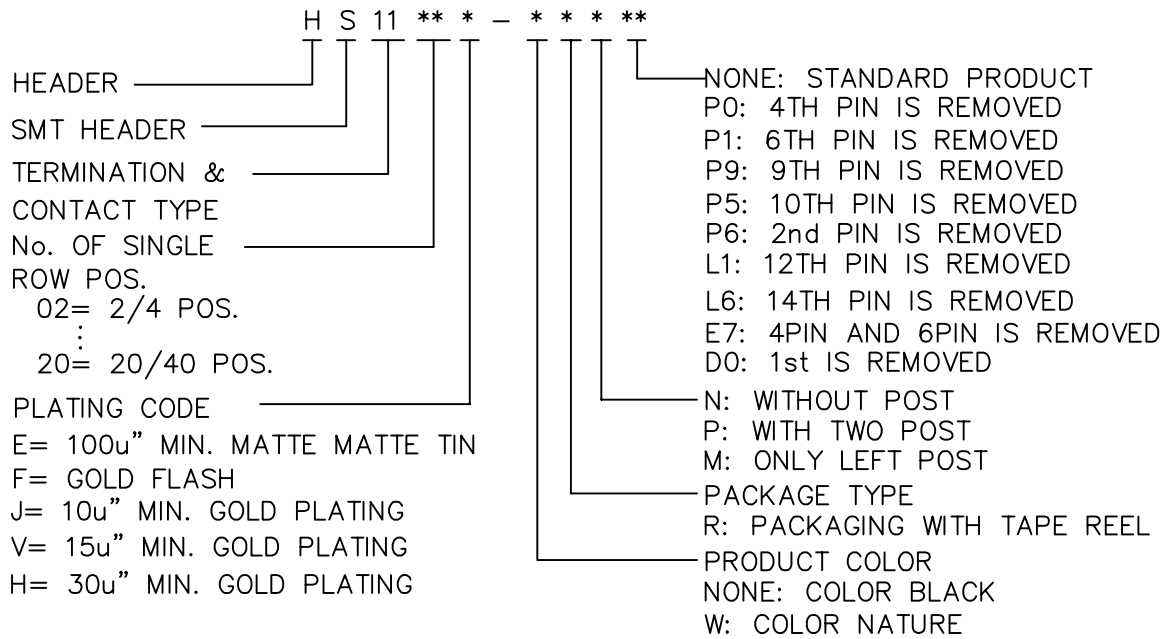

- HARMFUL MATERIAL CONTROL PLEASE FOLLOW FOXCONN'S DOC. "EPI12".
- PLEASE CONTACT FOXCONN SALES REPRESENTATIVE TO VERIFY PRODUCT DETAIL & AVAILABILITY.
- THE CONCENTRATIONS OF Br&Cl CAN SATISFY THE REQUIREMENT OF HALOGEN-FREE IN DOCUMENT "EPI12".

**FOXCONN** HON HAI PRECISION IND. CO.,LTD.  
TAIPEI, TAIWAN, R.O.C.

E	BC-09-7074908	Yihsin Chen
D	BC-09-7050172	Yihsin Chen
C	BC-08-7157760	Jake W.Y
B	BC-08-7054571	Jake W.Y
A	BC-07-705532	Yusan
REV.	ECN NO.	APPD.

APPD. : Yihsin Chen	TITLE : MATERIAL SHEET HEADER CONN., SMT	
CHKD. : Wolfe Liu	PROD. SERIES : HS11 SERIES	
DR. : Fenghua Yu	DWG. NO : 307-0500-241	
7/13'09	REV. : E	SHEET : 1/1

# SPECIFICATIONS :

## 1. PHYSICAL :

### 1-1. HOUSING :

HIGH TEMPERATURE , THERMOPLASTIC , UL94V-0

### 1-2. CONTACT :

COPPER ALLOY , 50u" MIN. NICKEL UNDER PLATING OVER ALL , 100u" MIN. MATTE TIN PLATING OVER NICKEL WITH RoHS COMPLIANCE. GOLD PLATING OVER NICKEL ON CONTACT AREA WITH RoHS COMPLIANCE.

### 1-3. PICK UP CAP:

HIGH TEMPERATURE , THERMOPLASTIC , UL94V-0 , COLOR BLACK.

## 2. ELECTRICAL CHARACTERISTICS :

2-1. CURRENT RATING : 3.0 A MAX. PER CONTACT.

2-2. LOW LEVEL CONTACT RESISTANCE : 30 MILLIOHMS MAX. INITIAL.

2-3. DIELECTRIC WITHSTANDING VOLTAGE : 1000V AC FOR 1 MINUTE.

2-4. INSULATION RESISTANCE : 1000 MEGOHMS MIN.

## 3. MECHANICAL CHARACTERISTICS :

3-1. RETENTION FORCE: 0.45Kgf MIN. PER CONTACT.

3-2. INSERTION FORCE: 0.50kgf MAX.PER POS..

3-3. WITHDRAWAL FORCE: 0.045kgf MIN.PER POS..

## 4. ENVIRONMENTAL DATA:

4-1. OPERATING TEMPERATURE : -40°C TO +105°C.

4-2. SOLDERABILITY : PASSED EIA-364-52.

4-3. HARMFUL MATERIAL CONTROL PLEASE FOLLOW FOXCONN'S DOC. "EPI12"

5. PLEASE CONTACT FOXCONN SALES REPRESENTATIVE TO VERIFY PRODUCT DETAILS & AVAILABILITY.

6. THE CONCENTRATIONS OF BR&CL CAN SATISFY THE REQUIREMENTS OF. HALOGEN-FREE IN DOCUMENT EP112.

**FOXCONN** HON HAI PRECISION IND. CO.,LTD.  
TAIPEI, TAIWAN, R.O.C.

APPD. : Jake W.Yuan

TITLE : SPECIFICATION  
SMT HEADER, VERTICAL

CHKD. : D.J.Chen

PROD. SERIES : HS11 SERIES

DR. : Yuke Chen  
2/24'09

DWG. NO : 307-0300-241

REV. : C SHEET : 1/1

C	BC097010947	Jake W.Yuan
B	BC087157814	Jake W.Yuan
A	BC07705530	Yusan
REV.	ECN NO.	APPD.