

REV.	ECN. No.	APPD.
A	IC01749	Yihsin Chen
B	IC021924	Yihsin Chen
C	HC0410856	Ady Zhou
D	HC067417	Ady Zhou

NOTE: UNLESS OTHERWISE SPECIFIED

1. DIMENSION SHALL BE INTERPRETED PER ASME Y14.5-2009.
2. SPEC. OF PROD. ARE SHOWN ON DRAWING 307-0000-931.
3. MATERIAL OF PROD. ARE SHOWN ON DRAWING 307-0000-930.
4. PROD.No.:

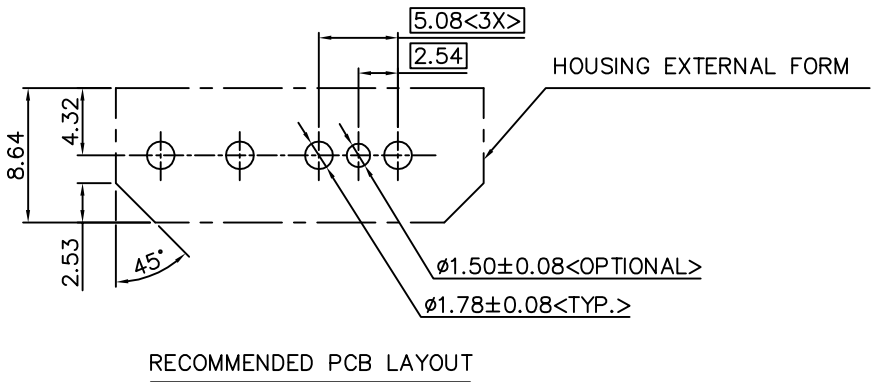
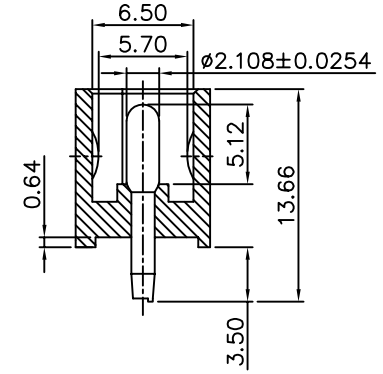
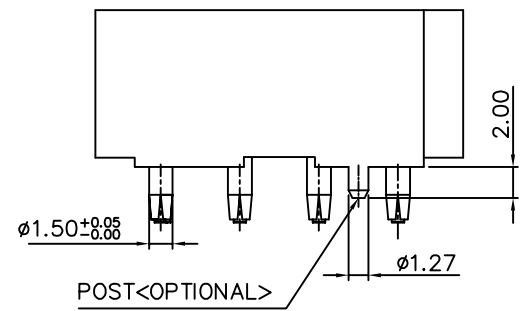
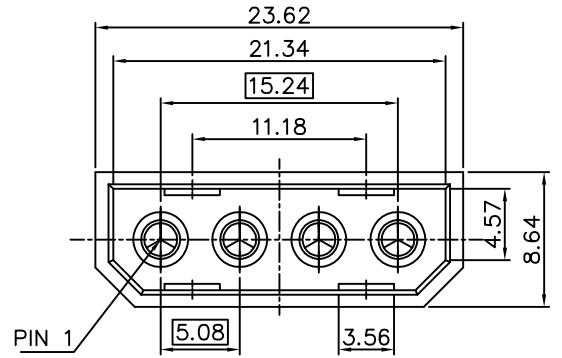

HM 22 \*\* \* - \* \*\* \* \* \*

POWER HEADER

PRODUCT SERIES:  
SINGLE ROW, 5.08mm PITCH,  
V/T, T/H

No. OF SINGLE ROW POS.  
04=4 POSITIONS

PLATING CODE  
E=100u" MIN. MATTE TIN PLATING  
(RoHS COMPLIANCE)

RoHS CODE  
F/NONE=RoHS PRODUCT  
H=RoHS&HALOGEN FREE  
HOUSING MAERIAL  
NONE/1: PA9T  
L: LCP  
PACKING TYPE:  
NONE/1: TRAY  
MODIFICTION CODE  
NONE/1: WITHOUT POST  
G1: ONE POST  
HOUSING COLOR  
NONE/1: BLACK  
W: WTIHE

5. PLEASE CONTACT FOXCONN SALES REPRESENTATIVE TO VERIFY PRODUCT DETAILS & AVAILABILITY.
6. HARMFUL MATERIAL CONTROL PLEASE FOLLOW DOC. NO. "EPI12".

X.±	X°.±	UNITS mm [INCH]	NAME(INTENDED USE)	FOXCONN						
.X± 0.38	.X°±	MAT'L	POWER CONN.	HON HAI PRECISION IND. CO.,LTD. TAIPEI, TAIWAN, R.O.C.						
.XX± 0.25	.XX°±	FINISH	PART NO.(INTENDED USE) HM22 SERIES	TITLE: CUSTOMER DRAWING						
.XXX±	.XXX°±		APPD: Shih-Wei Hsiao	DWG NO.: 308-0000-929						
THESE DRAWINGS AND SPECIFICATIONS ARE THE PROPERTY OF HON HAI PRECISION IND. CO., LTD. AND SHALL NOT BE REPRODUCED, COPIED OR USED IN ANY MANNER WITHOUT THE PRIOR WRITTEN CONSENT OF HON HAI PRECISION IND. CO., LTD.			Q'TY	CHKD: Yusan Hsiao						
				DR: Xu Liu 06/12'14						
				<table border="1"> <tr> <th>SCALE</th> <th>SHEET</th> <th>REV.</th> </tr> <tr> <td>N/A</td> <td>1/1</td> <td>DX2</td> </tr> </table>	SCALE	SHEET	REV.	N/A	1/1	DX2
SCALE	SHEET	REV.								
N/A	1/1	DX2								

ITEM	DESC.	Q'TY	MATERIAL	TREATMENT	REMARK
1	HOUSING	1	HIGH TEMP. THERMO-PLASTIC,UL 94V-0	COLOR SEE PRODUCT NO. MATRIX	
2	CONTACT	SEE NOTE BELOW	COPPER ALLOY	A) NICKEL PLATING OVER ALL THICKNESS : 50~150u". B) GOLD OR MATTE TIN WITH LEAD FREE PLATING OVER NICKEL. THICKNESS : 100~200u" .	

NOTE :

1 . PRODUCT NO. MATRIX :

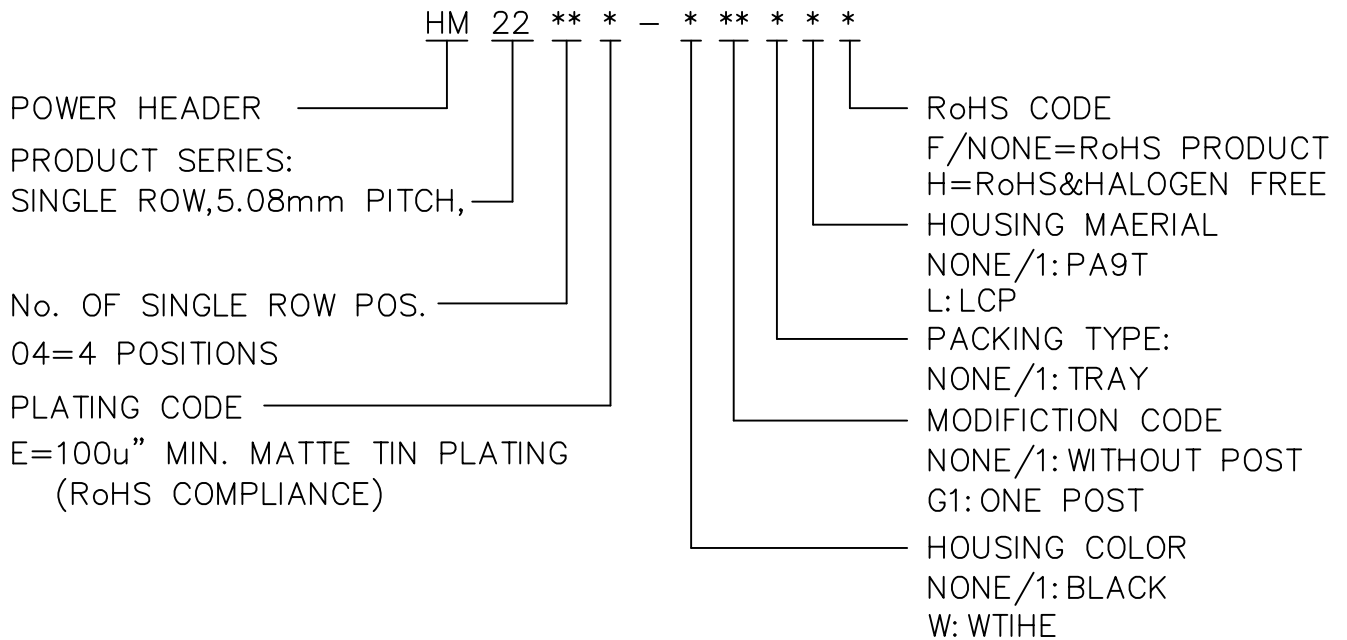

2 . HARMFUL MATERIAL CONTROL PLEASE FOLLOW DOC. No."EPI12"

3 . THE CONCENTRATIONS OF Br&Cl CAN SATISFY THE REQUIREMENTS OF HALOGEN-FREE IN DOCUMENT EPI12.

4 . PLEASE CONTACT FOXCONN SALES REPRESENTATIVE TO VERIFY PRODUCT DETAILS&AVAILABILITY.

**FOXCONN** HON HAI PRECISION IND. CO.,LTD.  
TAIPEI, TAIWAN, R.O.C.

APPD. : Shih-Wei Hsiao TITLE : MATERIAL DRAWING

CHKD. : Yusan Hsiao PROD. SERIES : HM22 SERIES

DR. : Xu Liu DWG. NO : 307-0000-930

06/12'14 REV. : AX2 SHEET : 1/1

A	IC017069	Yihsin Chen
REV.	ECN No.	APPD.

# SPECIFICATIONS :

## 1. MATERIAL :

### 1-1. HOUSING :

HIGH TEMP. THERMOPLASTIC , UL94V-0 , COLOR SEE PRODUCT NO. MATRIX.

### 1-2. CONTACT :

COPPER ALLOY.

## 2. PERFORMANCE :

2-1. VOLTAGE RATING : 250V AC

2-2. CURRENT RATING : 10A PER PIN.

2-3. TEMPERATURE RANGE: -25°C TO +85°C

(INCLUDING TEMPERATURE RISE IN APPLYING ELECTRICAL CURRENT)

2-4. DIELECTRIC WITHSTANDING VOLTAGE : 1500V AC/minute.

2-5. INSULATION RESISTANCE : 500 MEGAOHMS MIN.

2-6. CONTACT RESISTANCE: 5 MILLIOHMS MAX

## 3. MECHANICAL:

3-1. RETENTION FORCE: 1.82 kgf MIN. PER PIN.

4 . HARMFUL MATERIAL CONTROL PLEASE FOLLOW DOC. No."EPI12"

5 . THE CONCENTRATIONS OF Br&Cl CAN SATISFY THE REQUIREMENTS OF HALOGEN-FREE IN DOCUMENT EPI12.

6 . PLEASE CONTACT FOXCONN SALES REPRESENTATIVE TO VERIFY PRODUCT DETAILS&AVAILABILITY

**FOXCONN** HON HAI PRECISION IND. CO.,LTD.  
TAIPEI, TAIWAN, R.O.C.

APPD. : Shih-Wei Hsiao

TITLE :  
SPECIFICATION DRAWING

CHKD. : Yusan Hsiao

PROD. SERIES : HM22 SERIES

DR. : Yuke Chen

DWG. NO : 307-0000-931

5/15'13

REV. : AX1 SHEET : 1/1

A	IC017069	Yihsin Chen
---	----------	-------------

REV.	ECN NO	APPD.
------	--------	-------