

IDEAS GENERATED DRAWING, DON'T CHANGE BY HAND.

REV.	ECN. NO.	APPD.
A	BC-08-7071729	L.C Wu
B	BC-08-7152318	L.C Wu
C	BC-09-7012554	L.C Wu
D	BC-09-7054405	L.C Wu
E	BC-09-7076084	L.C Wu
F	BC-09-7090566	L.C Wu
G	BC-10-0051096	L.C Wu
H	BC-11-0029255	L.C Wu
J	BC-11-0063392	L.C Wu

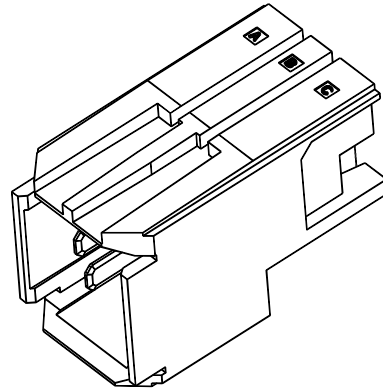

- NOTES: UNLESS OTHERWISE SPECIFIED;
- ELECTRICAL CHARACTERISTICS:
 - CURRENT RATING: 15A MAX. PER CONTACT AT 70°C.
 - CONTACT RESISTANCE TO BE 20 mOHMS MAX.
 - MECHANICAL CHARACTERISTICS:
 - THE MATING FORCE TO BE 1.5 N MAX. PER PIN.
 - THE UNMATING FORCE TO BE 0.3 N MIN. PER PIN.
- △ PRESS FIT HOLES:
- HOLE DIAMETER AFTER PLATING: 0.55~0.65mm.
 - DRILLED HOLE DIAMETER: 0.68~0.72mm.

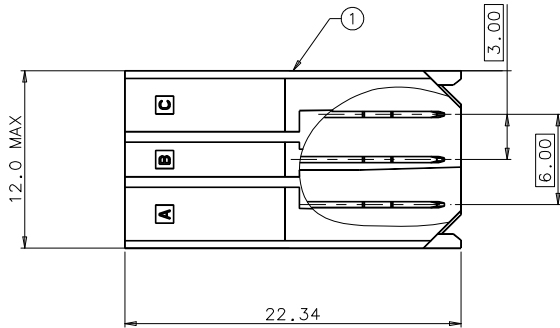
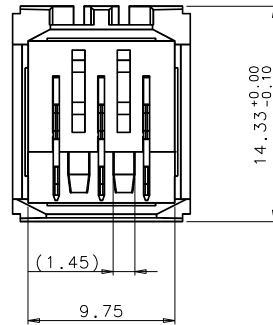
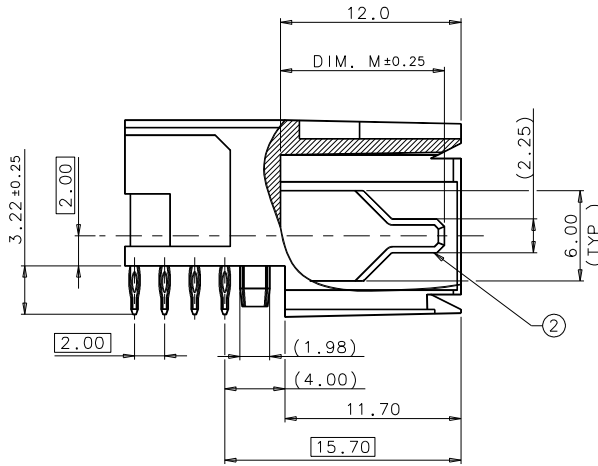

PART LIST

2 H 7 3 0 1 0 * - S 0 B 0 *

PLATING SPEC. IN CONTACT AREA: SEE THE TABLE.

SELECTIVE PIN PATTERN REFER TO NEXT PAGE

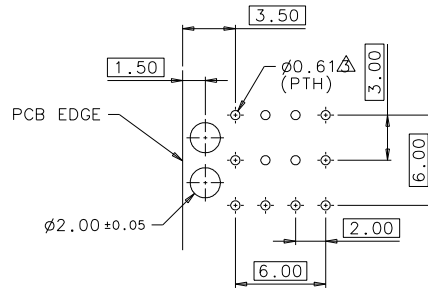
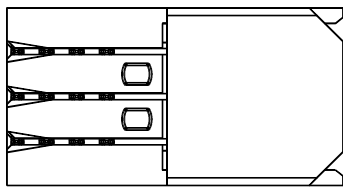

RECONNECTION PCB LAYOUT

NO.	PLATING SPEC.	PERFORMANCE LEVEL
1	GOLD FLASH	IEC PL 3
3	0.76um(30u*)MIN, FPT PLATING 0.076um(3u*)MIN, GOLD INCLUDED	IEC PL 2

ITEM	DESCRIPTION	MATERIAL	TREATMENT
2	CONTACT	PHOSPHER BRONZE	1)2.54um(100u*) MIN, NICKEL UNDER PLATING OVER ALL. 2)0.76um(30u*) MIN, TIN(LEAD FREE) PLATING ON PRESS FIT AREA. 3)PLATING SPEC. IN CONTACT AREA, DETAIL REFER TO PART LIST.
1	HOUSING	PBT	GRAY UL94-V0

X.±	0.50	X.*±	UNITS	mm	NAME (INTENDED USE)	FOXCONN HON HAI PRECISION IND. CO.,LTD. TAIPEI, TAIWAN, R.O.C.
.X±	0.20	.X*±	MAT*L		HARD METRIC HEADER POWER	
.XX±	0.10	.XX*±			PART NO. (INTENDED USE)	
.XXX±		.XXX*±	FINISH		2H73010*-#0B0*	
			Q*TY		APPD: L.C.WU 06/08'11	DWG NO.:
					CHKD: CARLOS 06/08'11	385-0000-121
					DR: BOB GU 06/08'11	SCALE SHEET REV.
						N/A 1/2 J

THESE DRAWINGS AND SPECIFICATIONS ARE THE PROPERTY OF HON HAI PRECISION IND. CO., LTD. AND SHALL NOT BE REPRODUCED, COPIED OR USED IN ANY MANNER WITHOUT THE PRIOR WRITTEN CONSENT OF HON HAI PRECISION IND. CO., LTD.

IDEAS GENERATED DRAWING, DON'T CHANGE BY HAND.

REV.	ECN. NO.	APPD.
------	----------	-------

PART NO.	POSITION	DIM.M
2H73010*-*0B04	C	7.68
	B	10.90
	A	9.30

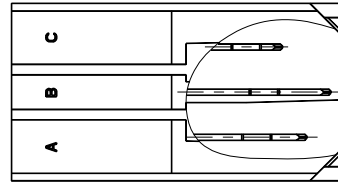

PART NO.	POSITION	DIM.M
2H73010*-*0B05	C	9.30
	B	10.90
	A	9.30

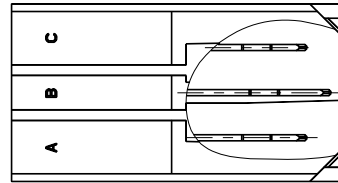

PART NO.	POSOTION	DIM.M
2H73010*-*0B06	C	10.90
	B	10.90
	A	10.90

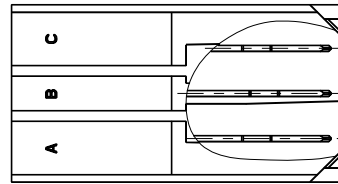

PART NO.	POSITION	DIM.M
2H73010*-*0B07	C	9.30
	B	9.30
	A	10.90

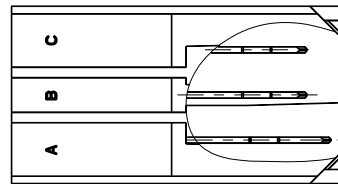

X. ±	X. ^o ±	UNITS mm	NAME (INTENDED USE) HARD METRIC HEADER POWER	FOXCONN HON HAI PRECISION IND. CO., LTD. TAIPEI, TAIWAN, R.O.C.
.X ± N/A	.X ^o ±	MAT'L	PART NO. (INTENDED USE) 2H73010*-*0B0*	TITLE: CUSTOMER DRAWING
.XX ± N/A	.XX ^o ±	FINISH	APPD: L.C.WU 06/08'11	DWG NO.: 385-0000-121
.XXX ±	.XXX ^o ±	Q'TY	CHKD: CARLOS 06/08'11	SCALE SHEET REV. N/A 2/2 J
THESE DRAWINGS AND SPECIFICATIONS ARE THE PROPERTY OF HON HAI PRECISION IND. CO., LTD. AND SHALL NOT BE REPRODUCED, COPIED OR USED IN ANY MANNER WITHOUT THE PRIOR WRITTEN CONSENT OF HON HAI PRECISION IND. CO., LTD.			DR: BOB GU 06/08'11	