



Asymmetric GTOs

Part number	V_{DRM}	V_{DC}	V_{RRM}	I_{TGQM} at C_S		I_{TAVM}	I_{TSM}	V_T	V_{T0}	r_T	T_{VJM}	R_{thJC}	R_{thCH}	F_m	Housing
						$T_C=85^\circ C$	10ms	I_{TGQM}	T_{VJM}						
						A	μF								
5SGA 15F2502	2500	1400	17	1500	3	570	10.0	2.80	1.45	0.90	125	27	8	15	F1
5SGA 20H2501	2500	1400	17	2000	4	830	16.0	2.80	1.66	0.57	125	17	5	20	H1
5SGA 25H2501	2500	1400	17	2500	6	830	16.0	3.10	1.66	0.57	125	17	5	20	H1
5SGA 30J2501	2500	1400	17	3000	5	1300	30.0	2.50	1.50	0.33	125	12	3	40	J
5SGA 06D4502	4500	2800	17	600	1	210	3.0	4.00	1.90	3.50	125	50	8	11	D1
5SGA 20H4502	4500	2200	17	2000	4	710	13.0	3.50	1.80	0.85	125	17	5	20	H1
5SGA 30J4502	4500	2800	17	3000	6	930	24.0	4.00	2.20	0.60	125	12	3	40	J
5SGA 40L4501	4500	2800	17	4000	6	1000	25.0	4.40	2.10	0.58	125	11	3	40	L

Asymmetric fine pattern GTOs with buffer layer

5SGF 30J4502	4500	3000	17	3000	3	960	24.0	3.90	1.80	0.70	125	12	3	33	J
5SGF 40L4502	4500	2800	17	4000	6	1180	25.0	3.80	1.20	0.65	125	11	3	40	L

Symmetric GTOs

Part number	V_{DRM}, V_{RRM}		I_{TGQM} at C_S		I_{TAVM}	I_{TSM}	V_T	V_{T0}	r_T	T_{VJM}	R_{thJC}	R_{thCH}	F_m	Housing
					$T_C=70^\circ C$	10ms	I_{TGQM}	T_{VJM}						
					A	μF								
5SGS 08D2500	2500		800	2	395	4.5	3.20	1.63	1.90	125	40.0	12.0	5	D2
5SGS 12F2500	2500		1200	3	630	10.0	3.20	1.49	1.38	125	24.0	8.0	10	F2
5SGS 16H2500	2500		1600	4	760	14.0	3.78	1.81	1.18	125	18.0	6.0	15	H2
5SGS 08D4500	4500		800	2	285	4.0	4.33	1.77	3.10	115	40.0	12.0	5	D2
5SGS 12F4500	4500		1200	3	442	7.6	4.50	2.28	1.79	115	24.0	8.0	10	F2
5SGS 16H4500	4500		1600	4	600	12.0	4.45	2.30	1.30	115	18.0	6.0	15	H2

Please refer to page 73 for part numbering structure.

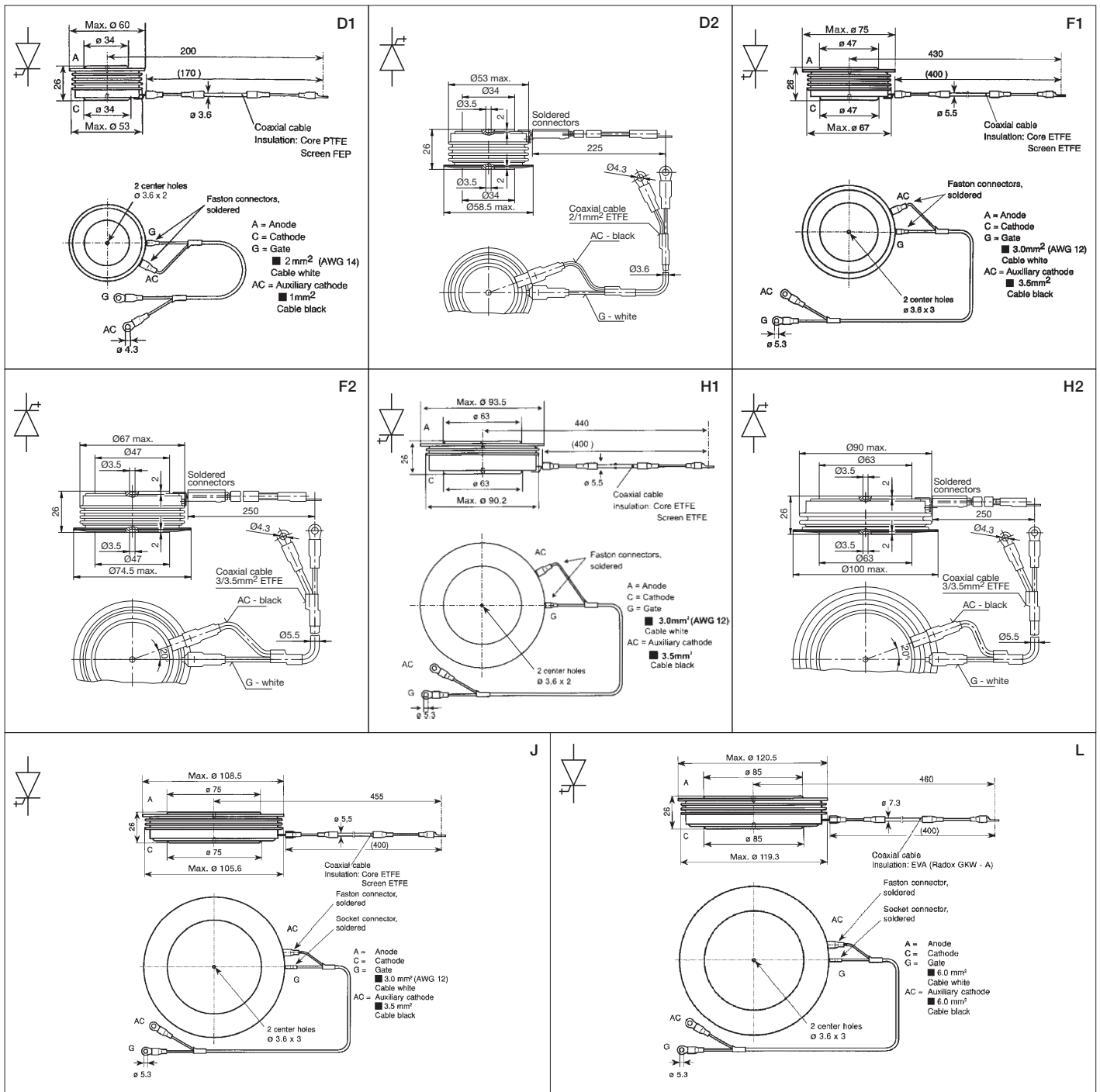

Dimensions in mm

Fast recovery diode recommendation

For all GTO types, ABB offers matching free-wheeling and snubber diodes.

The actual choice of the diode depends on the specific application. Please see application note 5SYA 2064, Applying fast recovery diodes, on www.abb.com/semiconductors.